

# The WaterMan project

## Feasibility study on dual pipe system for reuse of treated water in public building in Kalmar

Tobias Facchini

Region Kalmar County



# Challenge, background and objective

- Area of frequent droughts
- Buildings with existing dual-pipe system
- Hospital with high hygiene requirements

**Main objective to study a possible secure system to receive reclaimed wastewater for buildings with a dual pipe system**



Public pressurized water well with recovered WW

Production of reclaimed WW in UF-plant



Connection point distribution pipe; 5-6 bar  
Dosage of NaOCl to distribution pipe = micorbiological barrier no 2

Pressurized system with UV as  
microbiological barrier no 1

Connection point distribution pipe  
5-6 bar

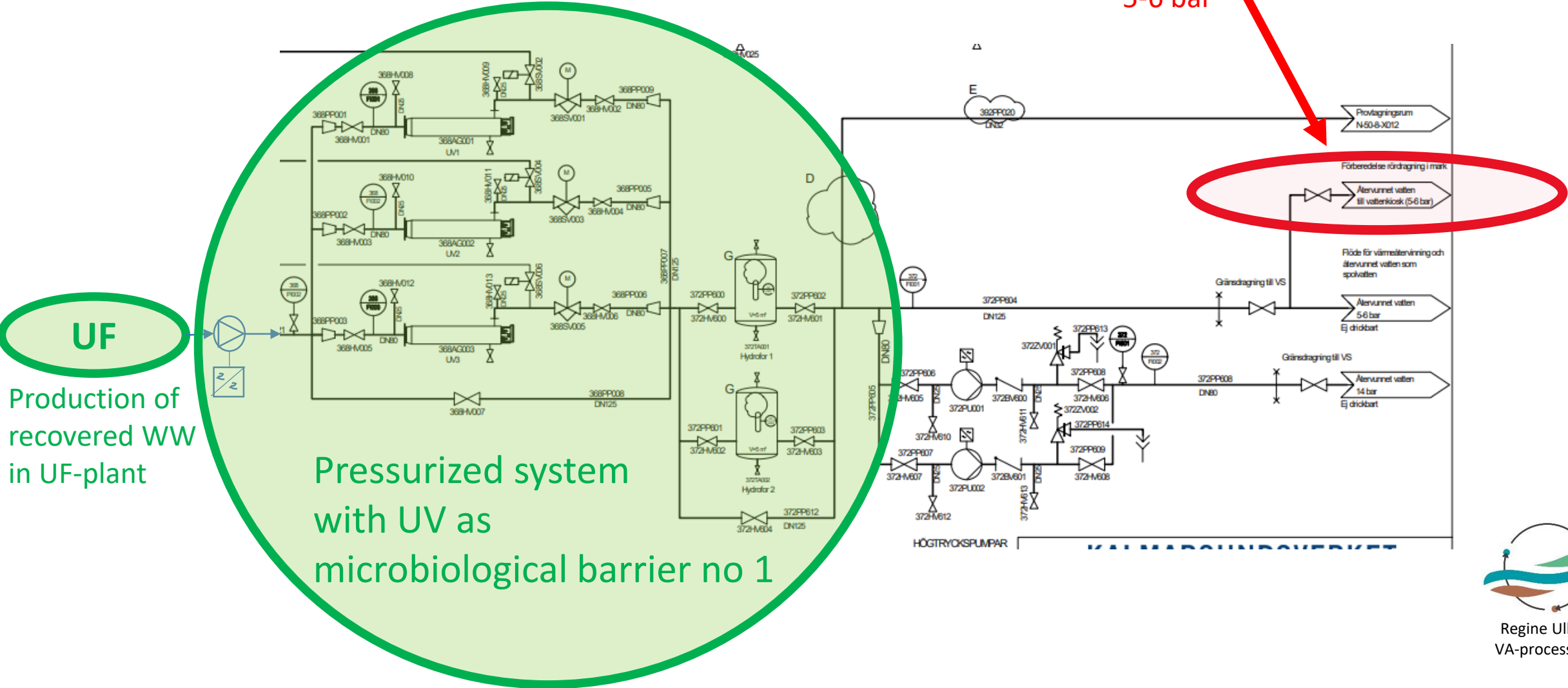

UF

Production of  
recovered WW  
in UF-plant

Pressurized system  
with UV as  
microbiological barrier no 1



Regine Ullman  
VA-processer AB

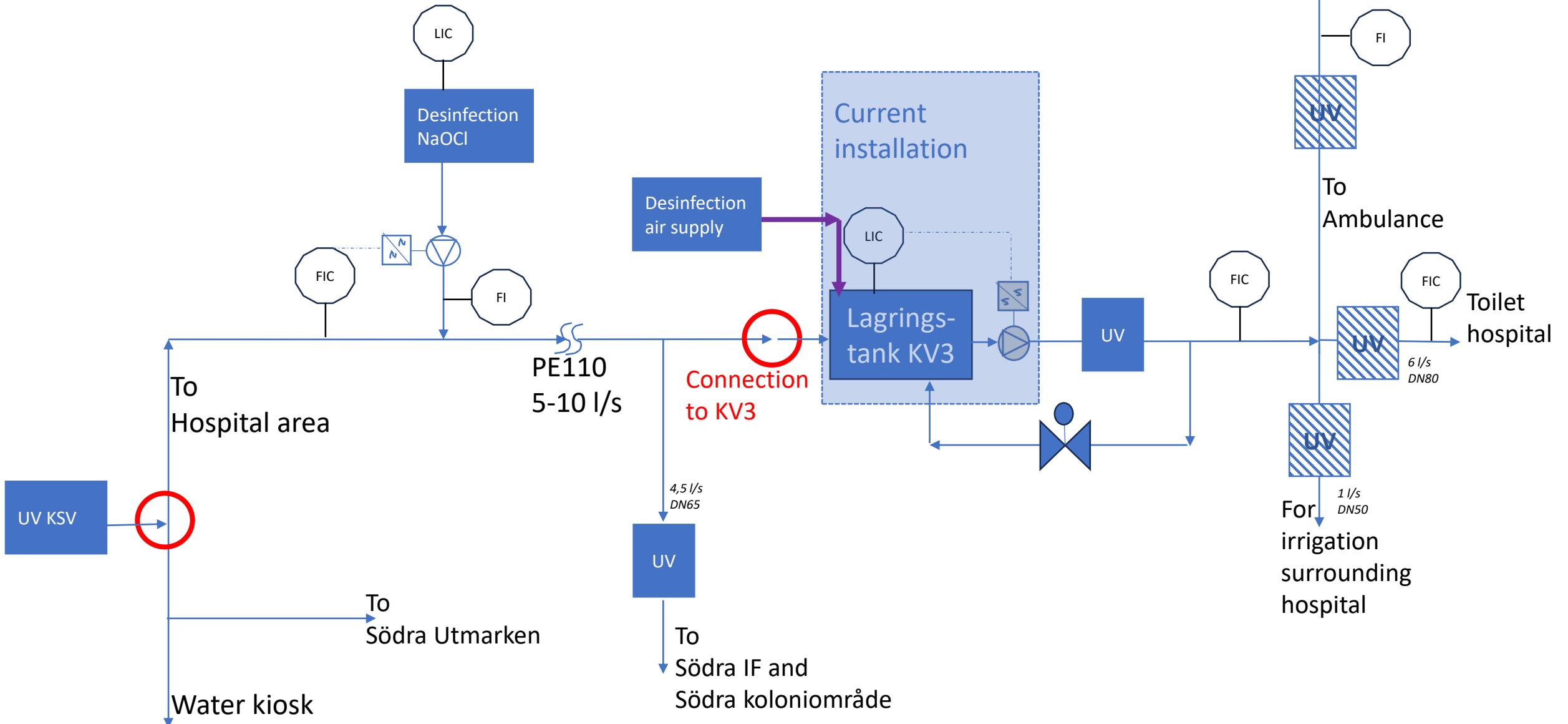

# Technical design – WATERMAN Dual-pipe

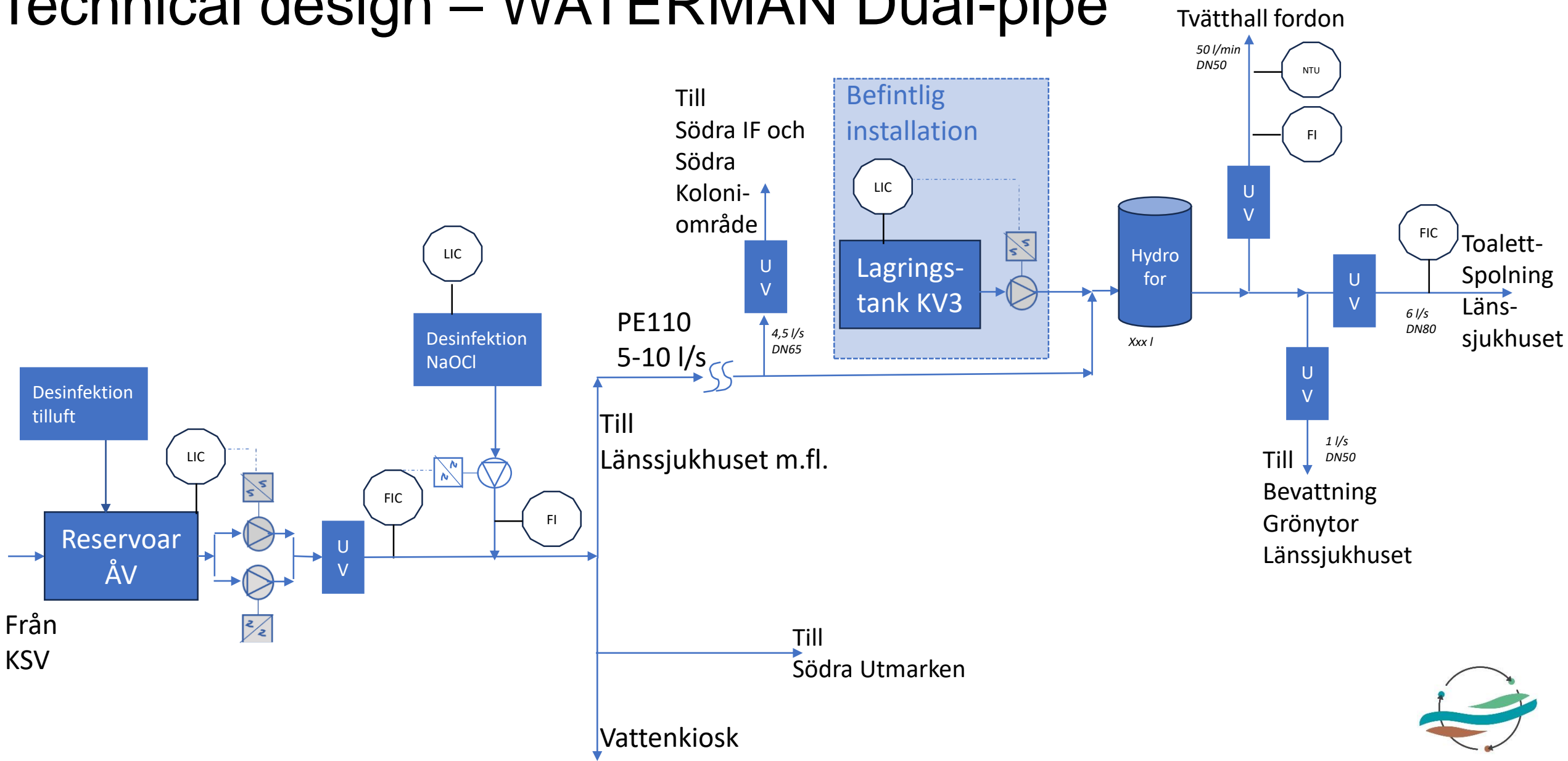

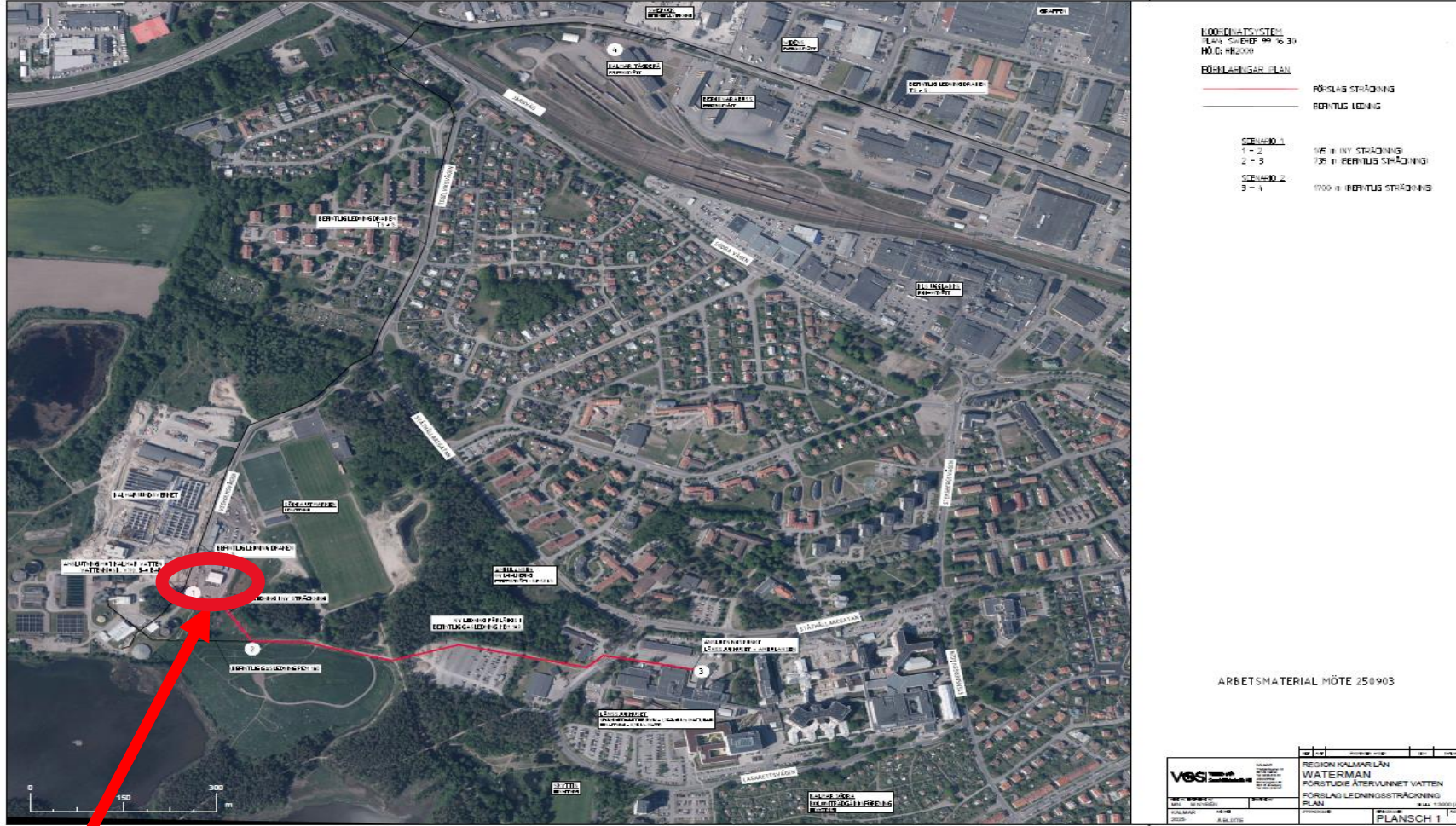

Connection point distribution pipe; 5-6 bar  
Dosage of NaOCl to distribution pipe = microbiological barrier no 2

Final concept, 31 Dec 2025

## Volymes and area of use

User	Area of use	Consumption					Comment
		m <sup>3</sup> /år	m <sup>3</sup> /dygn	m <sup>3</sup> /h (normal max)	l/min	l/s	
KV3 WC	Toilet flushing	91 250	250	12			365 d/år
Irrigation	Hospital plantations	610	3	2,6			Bevattning förutsätts ske halva ske halva året med 8h/d 8h/d (under natten).
	Hospital gras	3 000	16				
	Hospital new pond	180	1				
Future Ambulance Ambulance	Car wash				50	5-10	Bedöms som högt värde. värde. Bör innebära framtida möjligheter för nyttjande för nyttjande för tvätt.

## Final reflections – external consultant

- **Biggest surprise** – Hygiene experts within Kalmar region had same conclusions as own risk assessment
- **Tough moments** – solutions more expensive than first predicted
- **Tips and insights** – during the whole work process crucial to have a transparent and open dialogue with all key stakeholders
- **Future wish** – Full-scale pilot

# Recommendations & next steps

- Aim to proceed to piloting
- Further investigations needs to be carried out
- KSV not in place before 2027
- Estimated and possible financing still unclear
- Stakeholder group needs to be identified and developed



**Helpdesk / Contacts for further information:**

Tobias Facchini

[tobias.facchini@regionkalmar.se](mailto:tobias.facchini@regionkalmar.se)

The „BSR Water Recycling Toolbox” was elaborated as part of the project “WaterMan - Promoting water reuse in the Baltic Sea Region through capacity building at local level”, The project is co-financed by the European Union (European Regional Development Fund) and implemented within the Interreg Baltic Sea Region Programme. More information:

[eurobalt.org/WaterRecyclingToolbox](https://eurobalt.org/WaterRecyclingToolbox)  
[interreg-baltic.eu/project/waterman](https://interreg-baltic.eu/project/waterman)

WaterMan promotes a region-specific approach to water recycling, which intends to use the alternation of too much and too little water that has become typical in the Baltic Sea Region to make the local water supply more resilient, and supports municipalities & water companies in adapting their strategies.

*The contents of „BSR Water Recycling Toolbox” are the sole responsibility of the authors and can in no way be taken to reflect the views of the European Union, the Managing Authority or the Joint Secretariat of the Interreg Baltic Sea Region Programme.*

